

Technical Service Information

BMW transmission ZF version 5HP-30 service and repairs

BMW ZF-5HP-30 PRELIMINARY INFORMATION

840cia E31	92-96
740ia & 740il E38	94-97
750il & 850cia E31 & e38	94-Current
540ia E34, 740ia, & 740il E32	91-95

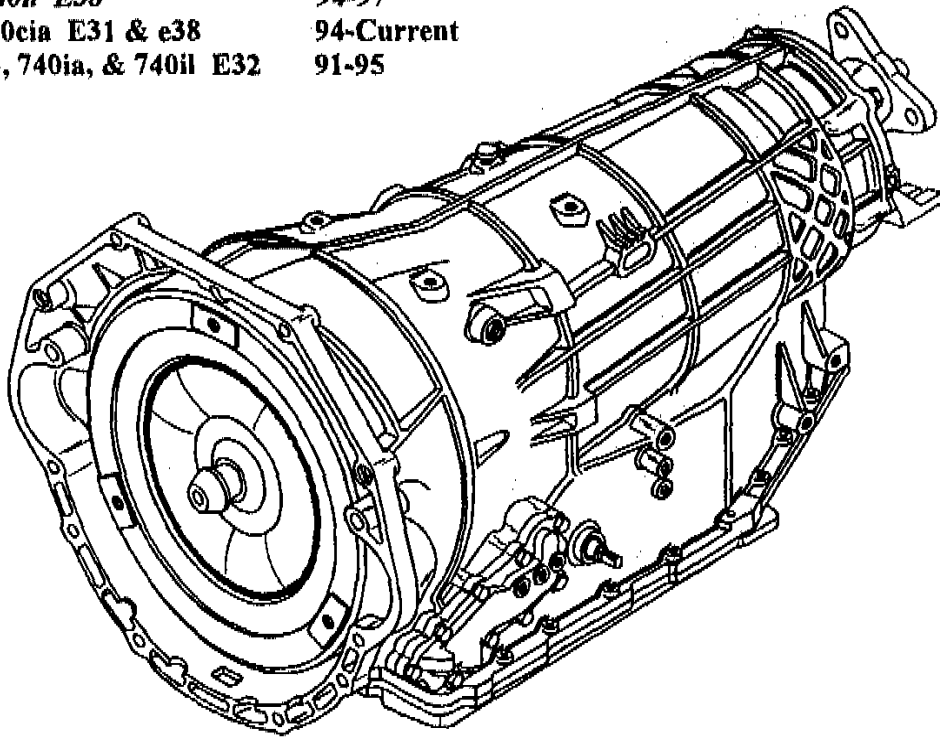

This transmission is manufactured in Germany by ZF and carries the BMW designation A5S 560Z.

The A5S 560Z is an electronically controlled, five speed automatic transmission with a lock-up clutch type torque converter. Three planetary gear sets (Wilson Gearing), three rotating multiple disc clutches, four multiple disc brake clutches, and two sprag clutches (Freewheels) are used to provide the five forward speeds and reverse.

Key to designation:

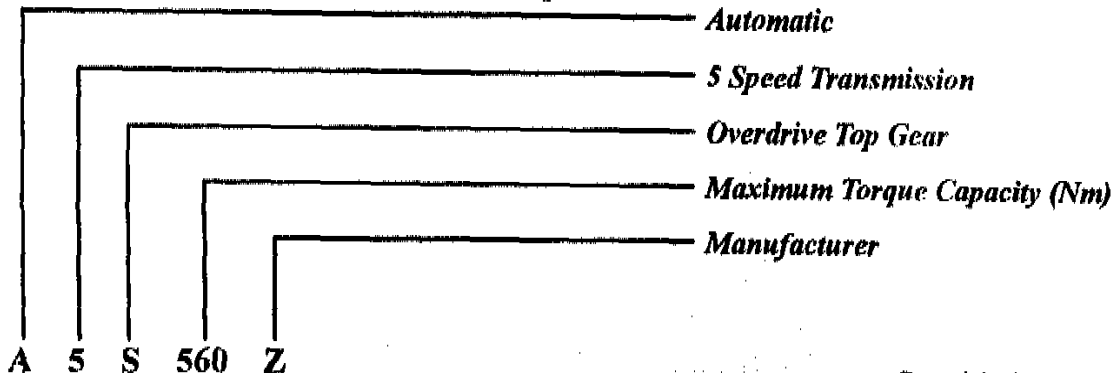

Copyright © 1998 ATSG

AUTOMATIC TRANSMISSION SERVICE GROUP

98-60
Page 1 of 16

Technical Service Information

BMW ZF-5HP-30

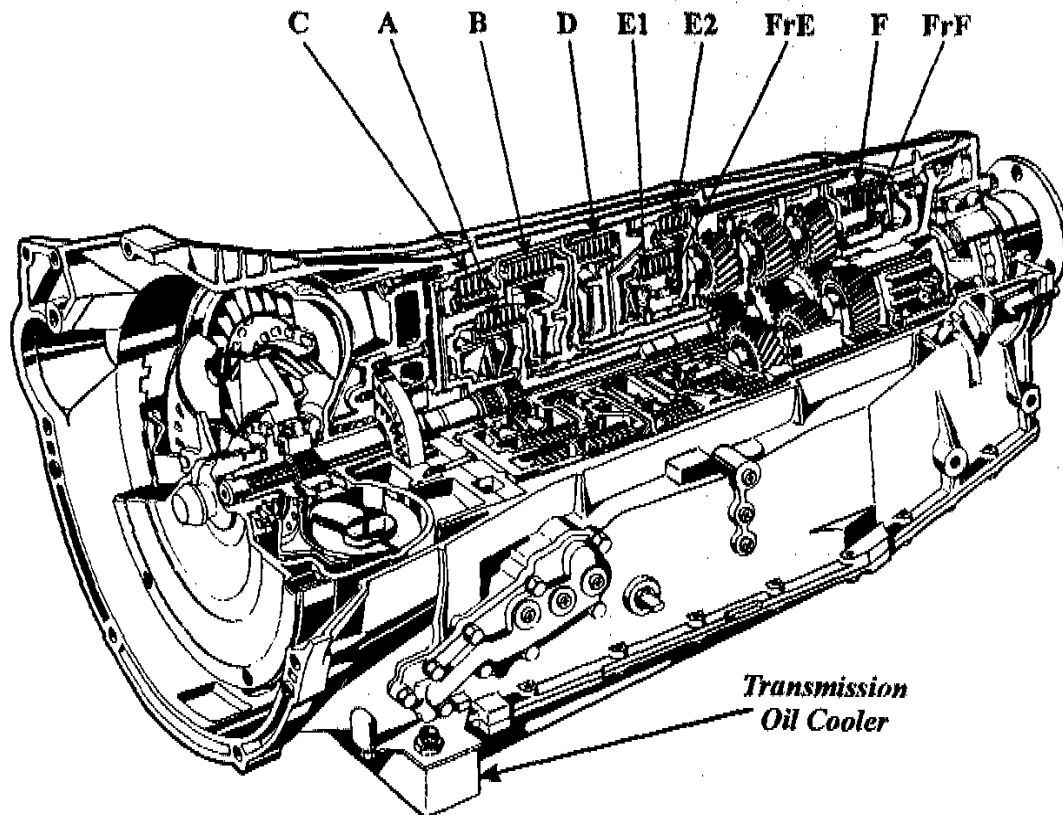

The oil cooler is a separate unit mounted on the underside of the transmission just ahead of the oil pan. The connections to the transmission oil supply are integrated into the mounting. The two external fittings visible are the supply and return lines for engine coolant. Full flow is maintained through the cooler at all times.

GEAR	"A" CLUT	"B" CLUT	"C" CLUT	"D" CLUT	"E1" CLUT	"E2" CLUT	"F" CLUT	"FrE" SPRAG	"FrF" SPRAG	GEAR RATIO
PARK							ON			
REV			ON	ON			ON			3.68:1
NEUT							ON			
D-1ST	ON								HOLD	3.55:1
D-2ND	ON				ON	ON		HOLD		2.24:1
D-3RD	ON			ON	ON					1.54:1
D-4TH	ON	ON			ON					1.00:1
D-5TH		ON		ON	ON					0.79:1
M-2	ON						ON			

Technical Service Information

NORMAL OPERATION:

A console mounted tip switch allows the driver to select either the Automatic or Winter mode. The Winter mode is designated by an ice crystal symbol (*) on the program switch. When in the Winter mode, the transmission starts off in 2nd gear and the upshifts are programmed to occur earlier to reduce the torque at the drive wheels and prevent wheel spin. The following chart explains the gear selection and each program mode based on the selector lever position.

SELECTOR LEVER POSITION	PROGRAM MODE	
	AUTOMATIC (A)	WINTER (*)
P	P	P
R	R	R
N	N	N
D	<i>D - Economy Program</i>	<i>D - Starts In 2nd, Early Upshifts 2-5</i>
4	<i>4 - Sport Program Delayed Upshifts 1-4</i>	<i>4 - Starts In 2nd, Early Upshifts 2-4</i>
3	<i>3 - Sport Program Delayed Upshifts 1-3</i>	<i>3 - Starts In 2nd, Early Upshifts 2-3</i>
2	<i>2 - Sport Program Delayed Upshifts 1-2</i>	<i>2 - Locked In 2nd</i>

ADAPTIVE SHIFT CONTROL:

Stop and Go Function:

When the transmission control module detects that the vehicle is being driven in a heavy traffic situation with many stops and starts at very low road speed, it will begin using 2nd gear when pulling away. Starting in 2nd gear and not downshifting to 1st gear when stopping eliminates the feeling of excessive load reversals, and provides a more comfortable driving style in this situation.

Deceleration Rate:

Typically, automatic transmission software programs will upshift to the highest gear possible when driven at a given road speed with no throttle application. The transmission control module on the A5S 560Z monitors the rate of change in throttle position when the throttle is released. If the throttle is released quickly, the transmission will stay in the present gear engaged, in anticipation of the drivers intent to slow down. If the throttle is gradually released, as when approaching desired road speed, the transmission will upshift to the next highest possible gear for that road speed.

FAILSAFE OPERATION:

When a system fault is detected which would impair normal reliable operation, the transmission control module interrupts the power supply to Pin 12 at the transmission case connector. The transmission control module also alerts the driver of any faults by signaling the vehicles "check control" system. To enable the vehicle to be driven to a repair shop, the following manual gear selections are permitted:

<i>Selector Lever Position</i>	P R N D 4 3 2
<i>Actual Gear Obtained</i>	P R N 4 4 4 4

ZF-5HP-30 UPPER REAR VALVE BODY

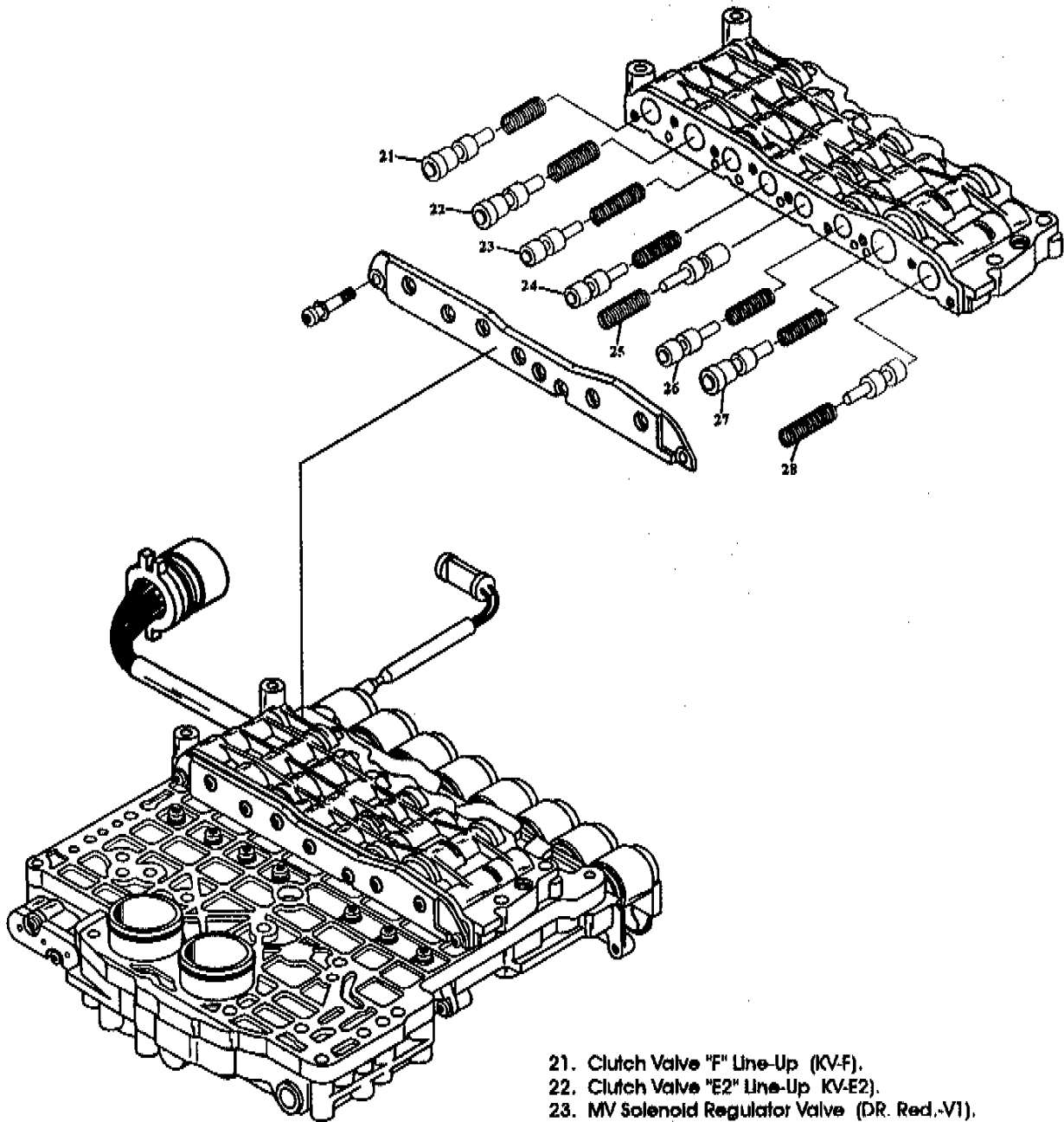

- 21. Clutch Valve "F" Line-Up (KV-F).
- 22. Clutch Valve "E2" Line-Up KV-E2).
- 23. MV Solenoid Regulator Valve (DR. Red.-V1).
- 24. EDS Solenoid Regulator Valve (DR. Red.-V2).
- 25. Clutch Valve "B" Line-Up (KV-B).
- 26. Clutch Valve "E1" Line-Up (KV-E1).
- 27. Switch Valve For "A" Clutch (ABSCH-V-A).
- 28. Clutch Valve "A" Line-Up (KV-A).

Copyright © 1998 ATSG

ZF-5HP-30 LOWER FRONT VALVE BODY

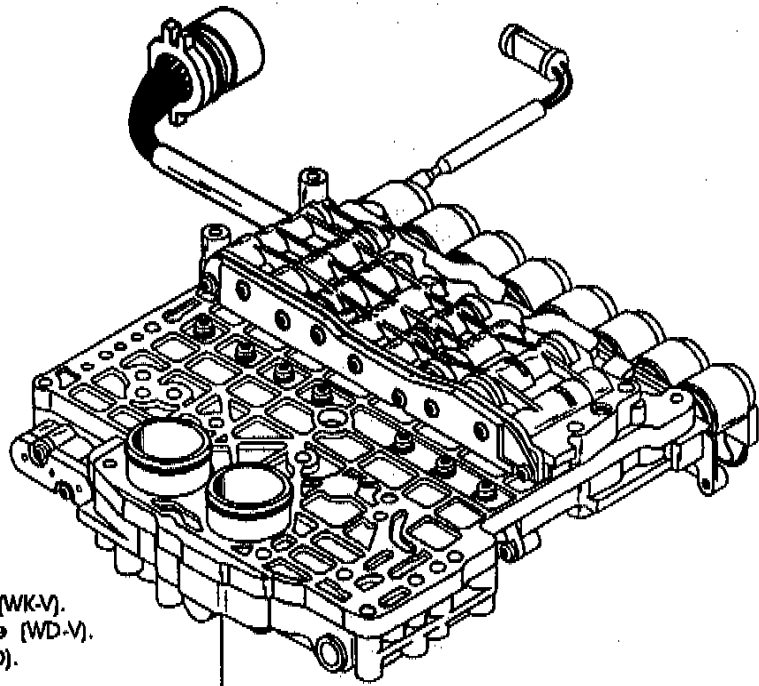

9. Manual Shift Valve (W-S).
10. Converter Clutch Apply Oil Control Valve (WK-V).
11. Converter Clutch Release Oil Control Valve (WD-V).
12. Main Pressure Regulator Valve Line-Up (HD).
13. Lubrication Valve (SCHM-V).
14. Modulating Valve Line-Up (MOD-V).
15. Main Regulator Valve For "B" Clutch (HV-B).
16. Accumulator Valve For EDS 2 Solenoid (D-2).
17. Main Regulator Valve For "D" Clutch (HV-D).
18. Accumulator Valve For EDS 4 Solenoid (D-4).
19. Accumulator Valve For EDS 5 Solenoid (D-5).
20. Accumulator Valve For EDS 3 Solenoid (D-3).

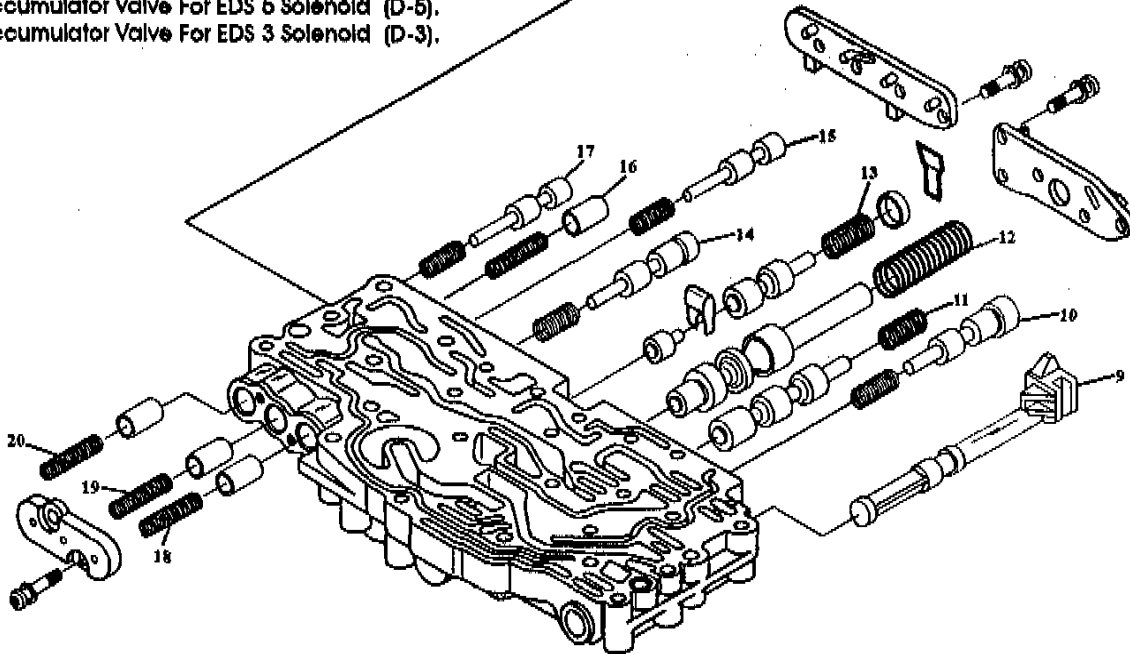

Copyright © 1998 ATSG

ZF-5HP-30 LOWER REAR VALVE BODY

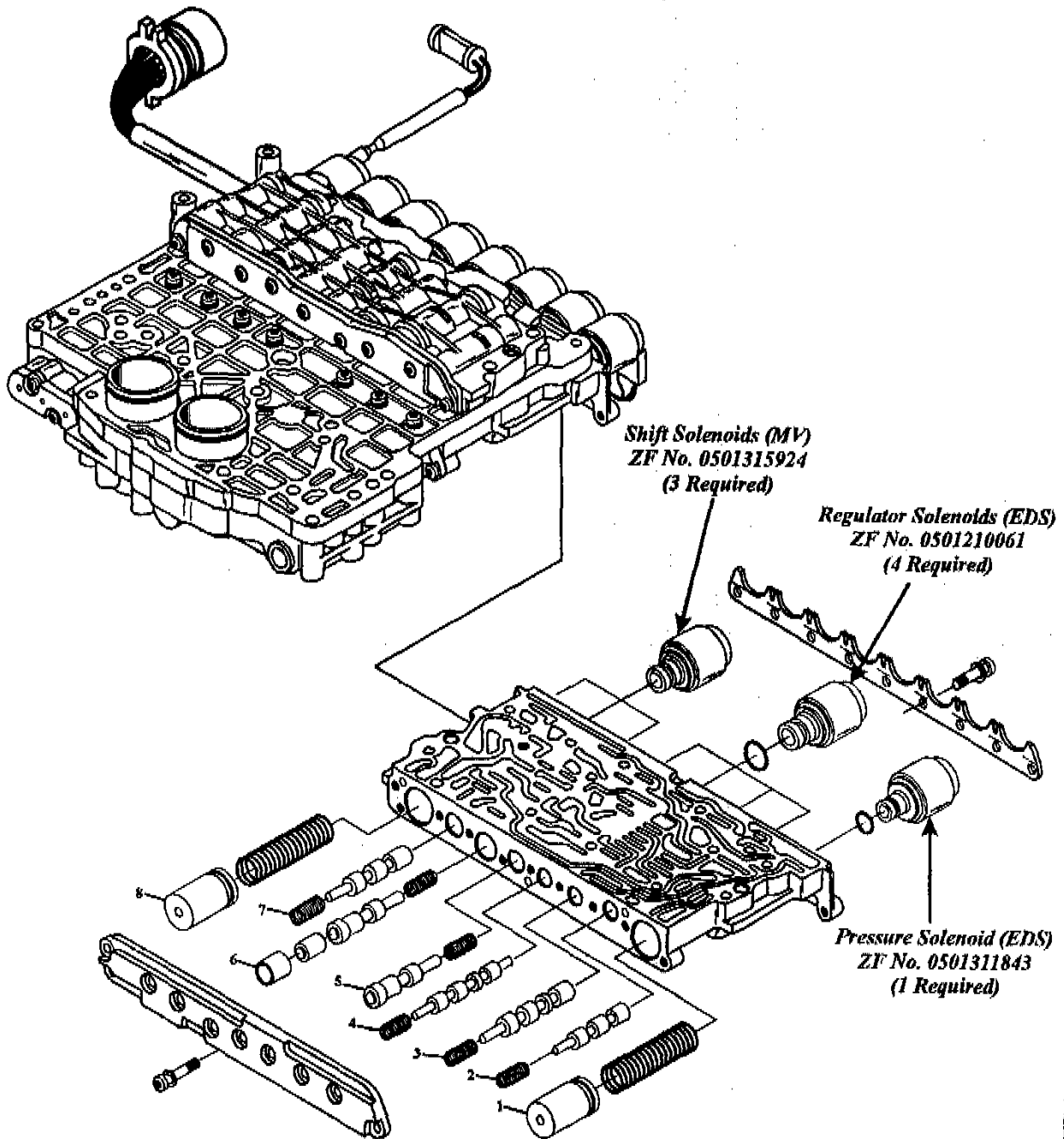

1. "A" Clutch Accumulator Line-Up (D-A).
2. Shift Valve Number 1 (SV-1).
3. Shift Valve Number 2 (SV-2).
4. Shift Valve Number 3 (SV-3).
5. Switch Valve For "D" Clutch (ABSCH-V-D).
6. Clutch Valve "D" Line-Up (KV-D).
7. Reverse Gear Valve Line-Up (RG-V).
8. "C" Clutch Accumulator Line-Up (D-C).

Copyright © 1998 ATSG

**ZF-5HP-30 CHANNEL PLATE
UPPER VALVE BODY SIDE**

Round Screen

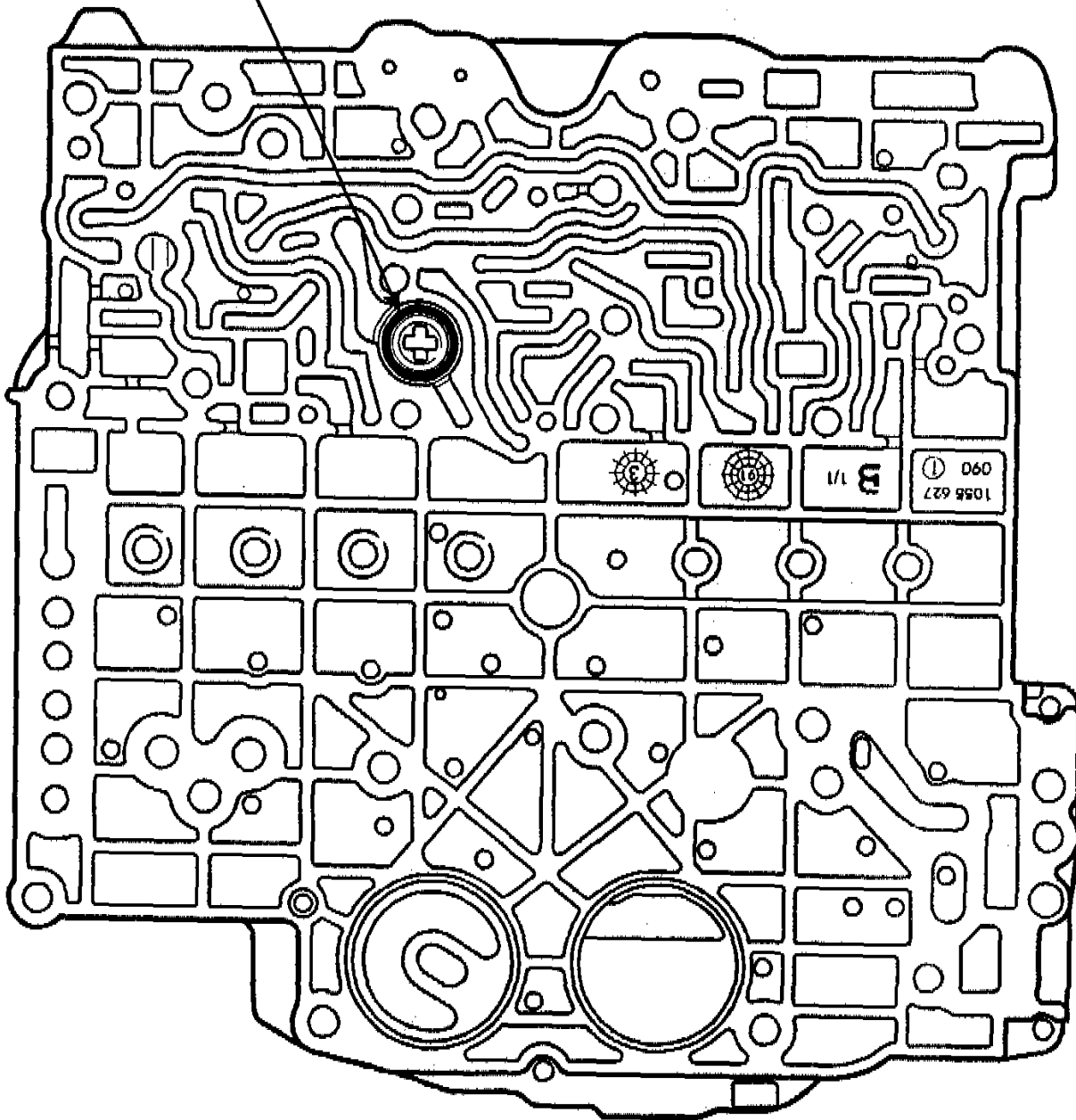
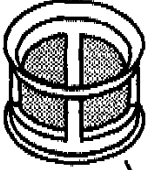

Copyright © 1998 ATSG

ZF-5HP-30 CHANNEL PLATE LOWER VALVE BODY SIDE

Replace the original ball with
a plastic .250" (6.35mm) ball.

Original
.236" Diameter

.039"
Flat Orifice

.048"
Flat Orifice

.048"
Flat Orifice

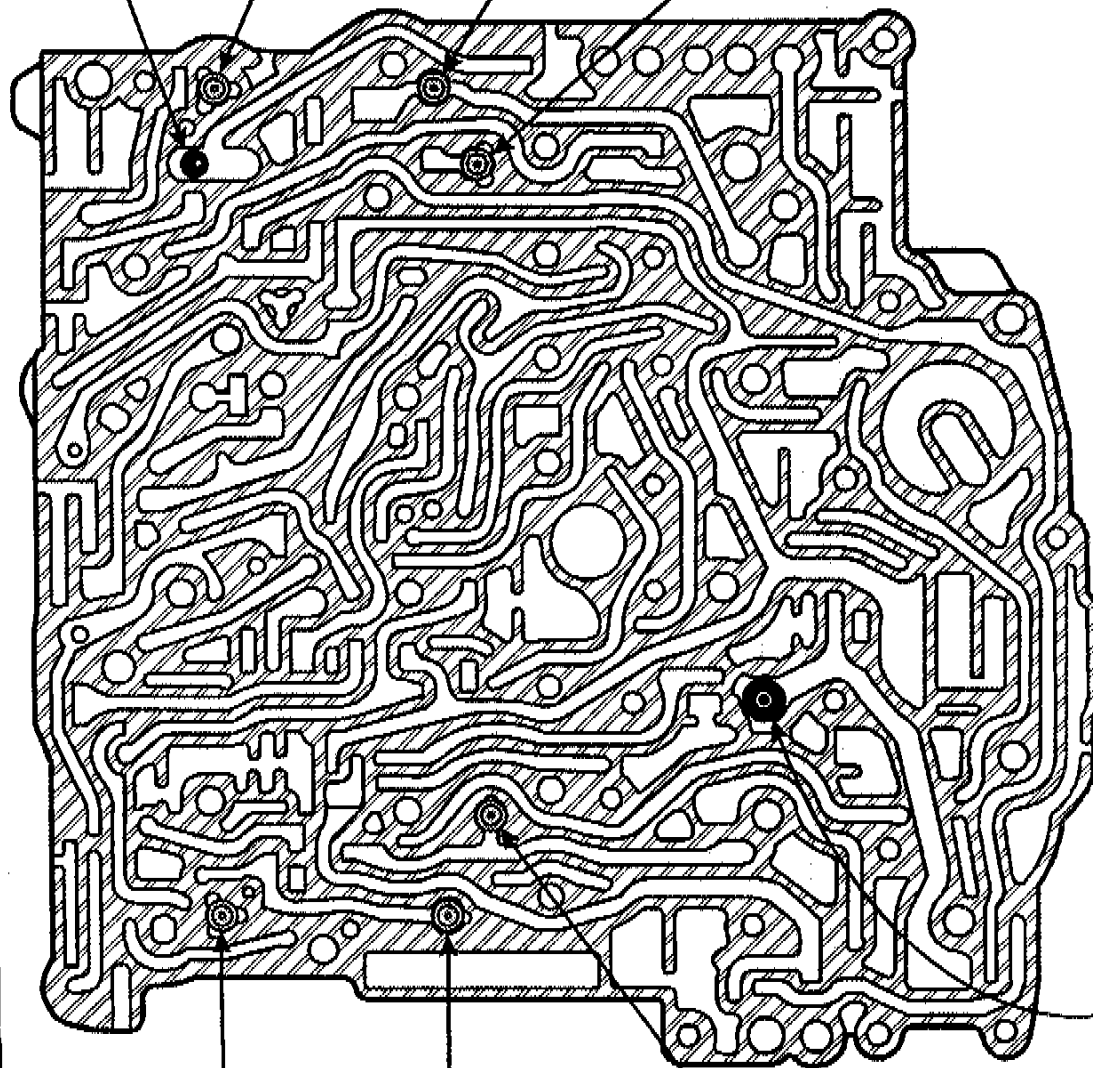

PLASTIC VALVE
AND SPRING

.039"
Flat Orifice

.048"
Flat Orifice

.067"
Flat Orifice

Copyright © 1998 ATSG

UPPER REAR VALVE BODY

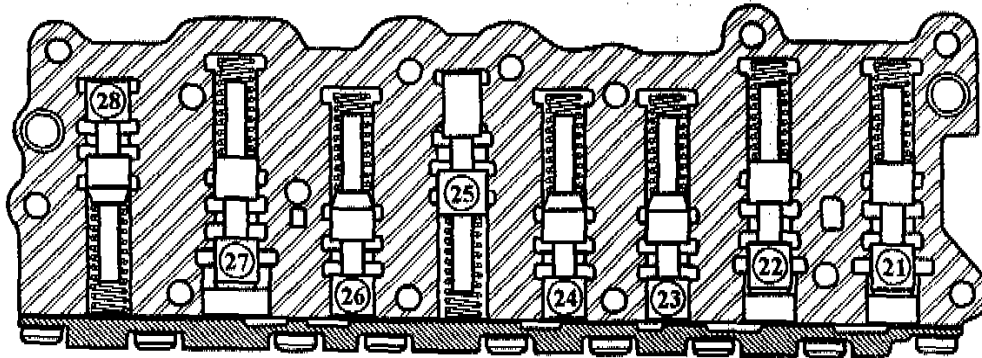

- 21. Clutch Valve "F" Line-Up (KV-F).
- 22. Clutch Valve "E2" Line-Up (KV-E2).
- 23. MV Solenoid Regulator Valve (DR. Red.-V1).
- 24. EDS Solenoid Regulator Valve (DR. Red.-V2).
- 25. Clutch Valve "B" Line-Up (KV-B).
- 26. Clutch Valve "E1" Line-Up (KV-E1).
- 27. Switch Valve For "A" Clutch (ABSCH-V-A).
- 28. Clutch Valve "A" Line-Up (KV-A).

*Only One .250" (6.35mm) ball is located here.
Do Not install a ball in the pocket marked X.*

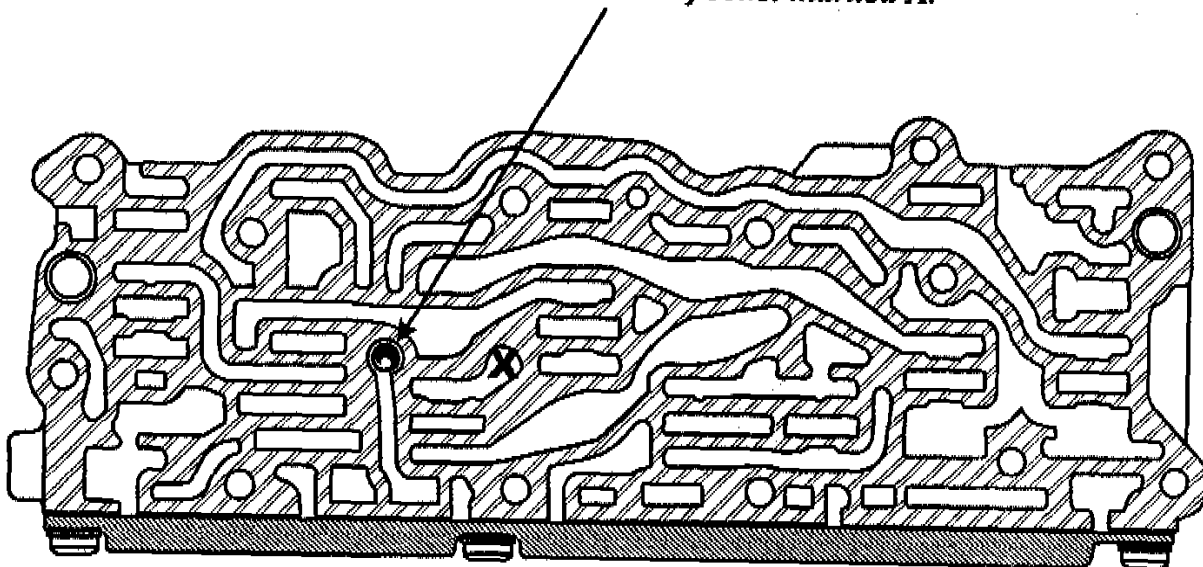



Technical Service Information

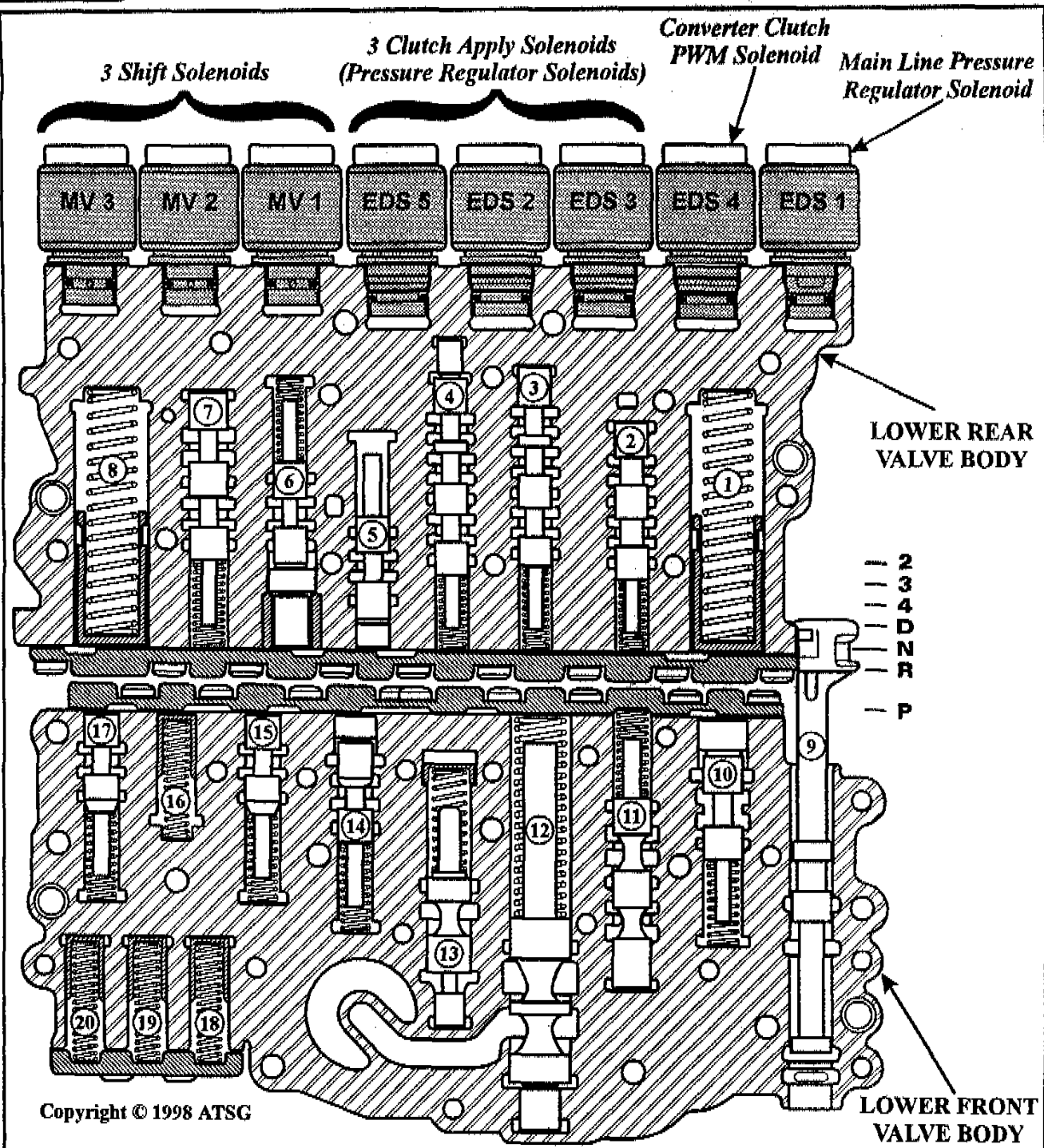

Copyright © 1998 ATSG

- | | |
|--|---|
| <ol style="list-style-type: none"> 1. "A" Clutch Accumulator Line-Up (D-A). 2. Shift Valve Number 1 (SV-1). 3. Shift Valve Number 2 (SV-2). 4. Shift Valve Number 3 (SV-3). 5. Switch Valve For "D" Clutch (ABSCH-V-D). 6. Clutch Valve "D" Line-Up (KV-D). 7. Reverse Gear Valve Line-Up (RG-V). 8. "C" Clutch Accumulator Line-Up (D-C). 9. Manual Shift Valve (W-S). 10. Converter Clutch Apply Oil Control Valve (WK-V). | <ol style="list-style-type: none"> 11. Converter Clutch Release Oil Control Valve (WD-V). 12. Main Pressure Regulator Valve Line-Up (HD). 13. Lubrication Valve (SCHM-V). 14. Modulating Valve Line-Up (MOD-V). 15. Main Regulator Valve For "B" Clutch (HV-B). 16. Accumulator Valve For EDS 2 Solenoid (D-2). 17. Main Regulator Valve For "D" Clutch (HV-D). 18. Accumulator Valve For EDS 4 Solenoid (D-4). 19. Accumulator Valve For EDS 5 Solenoid (D-5). 20. Accumulator Valve For EDS 3 Solenoid (D-3). |
|--|---|

ZF-5HP-30 INTERNAL WIRE SCHEMATIC

*View Looking Into Case
Connector Setting In The vehicle*

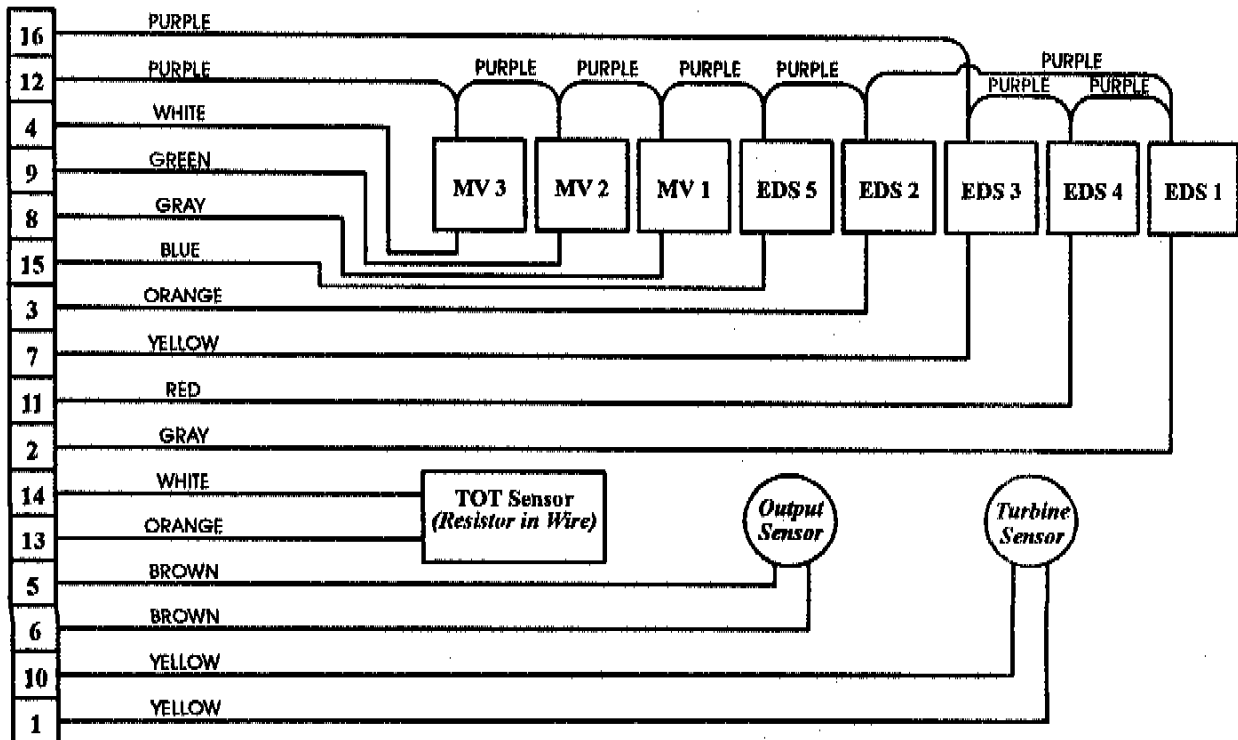
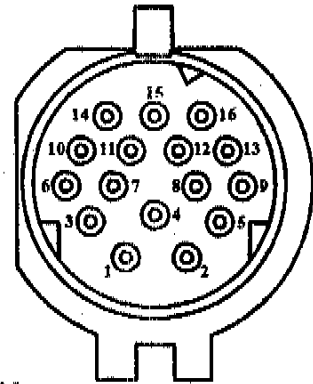
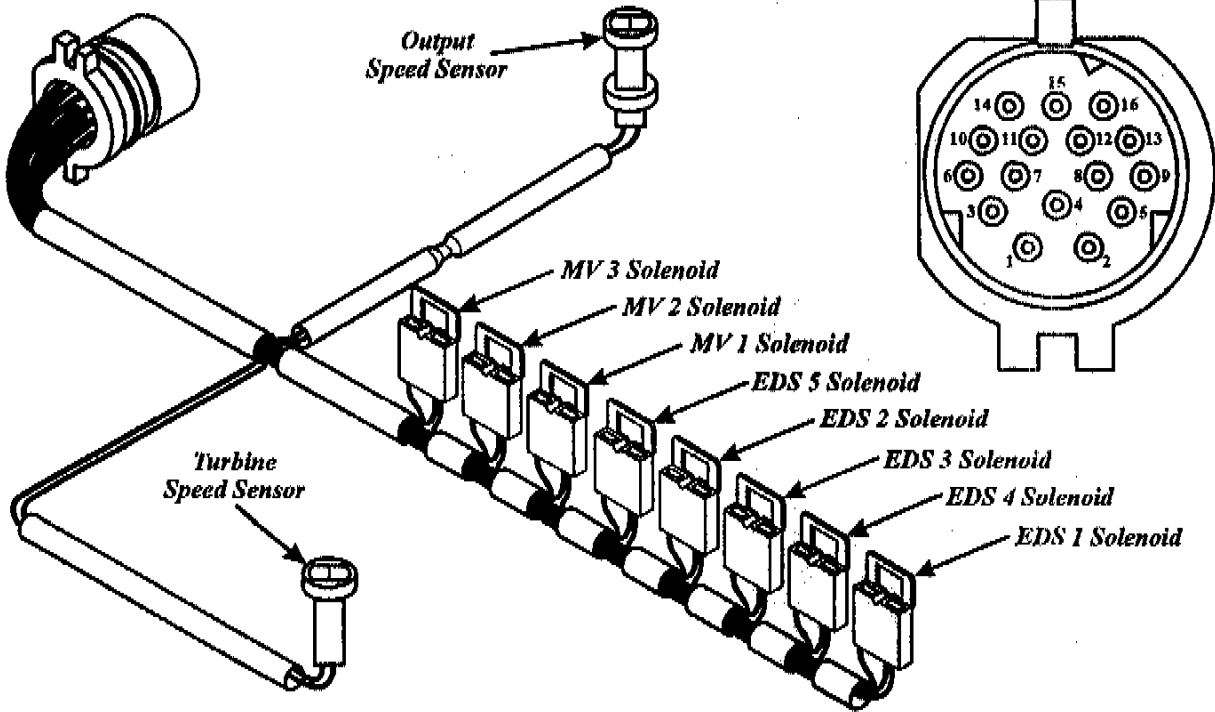

NOTE: Some internal wire colors may vary.

Copyright © 1998 ATSG



Technical Service Information

ZF-5HP-30 SOLENOID APPLICATION CHART

Selector Lever Position	MV 1 Solenoid	MV 2 Solenoid	MV 3 Solenoid	EDS 1 Solenoid	EDS 2 Solenoid	EDS 3 Solenoid	EDS 4 Solenoid	EDS 5 Solenoid	GEAR RATIO
PARK	ON			**					
REVERSE		ON	⊗	**	*-	*		*-	3.68:1
NEUTRAL	ON			**					
D-1ST	ON			**	*-	*-		*-	3.55:1
D-2ND	ON	ON		**		*		*	2.24:1
D-3RD		ON		**	*	*		*	1.54:1
D-4TH		ON		**	*-		-*-	*-	1.00:1
D-5TH			-*	**	*		-*-	*-	0.79:1
Failsafe (4th)	OFF	OFF	OFF	OFF	OFF	OFF	OFF	OFF	1.00:1

SOLENOID CHART LEGEND

Symbol	Description
ON	<i>MV 1, MV 2 and MV 3 Solenoids are energized by the Electronic Transmission Control unit and have two functions. They are Open or Closed. Energized (On), there is pressure in circuit.</i>
⊗	<i>MV 3 is turned "ON" if reverse is selected at a high vehicle speed, to inhibit reverse engagement.</i>
**	<i>EDS 1 is used for line pressure control only, and operates from 0 to 0.8 amps. When the solenoid is "OFF" (0 amps), pressure is high. EDS 1 pressure is "Lowered" as the solenoid is modulated by the control unit.</i>
*	<i>EDS 2, EDS 3, EDS 4 and EDS 5 Solenoids are also pulse modulated but are exactly the opposite of EDS 1 Solenoid. When these solenoids are "ON" oil pressure in the hydraulic circuit is high, and when they are "OFF" pressure in the hydraulic circuit is low.</i>
-*	<i>Solenoid "OFF" (hydraulic pressure low), then Solenoid "ON" (hydraulic pressure high).</i>
*-	<i>Solenoid "ON" briefly (hydraulic pressure high), then Solenoid "OFF" (hydraulic pressure low). The pressure acts briefly on regulator valves to cushion clutch application.</i>
-*-	<i>EDS 4 Solenoid is used for Torque Converter Clutch apply and release only, and depends on throttle position and vehicle speed as to its application.</i>

Copyright © 1998 ATSG

SOLENOID AND SENSOR RESISTANCE CHART

Solenoid	Case Connector	Control Unit Connector	Resistance In Ohms
	Pin Numbers	Pin Numbers	
MV 1	8 and 12	30 and 52	30 - 34 Ω
MV 2	9 and 12	33 and 52	30 - 34 Ω
MV 3	4 and 12	32 and 52	30 - 34 Ω
EDS 1	2 and 12	5 and 52	5.2 - 6.8 Ω
EDS 2	3 and 12	1 and 52	6.2 - 7.8 Ω
EDS 3	7 and 12	29 and 52	6.2 - 7.8 Ω
EDS 4	11 and 12	4 and 52	6.2 - 7.8 Ω
EDS 5	15 and 12	51 and 52	6.2 - 7.8 Ω
TOT	13 and 14	21 and 22	1000 Ω at 25° C
TSS	1 and 10	44 and 16	292 - 358 Ω
OSS	5 and 6	14 and 42	292 - 358 Ω

*View Looking Into Case
Connector Setting In The vehicle*

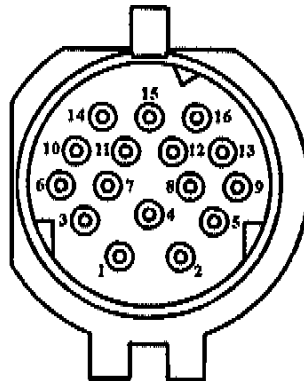

Electronic Control Unit Connector Pin Identification

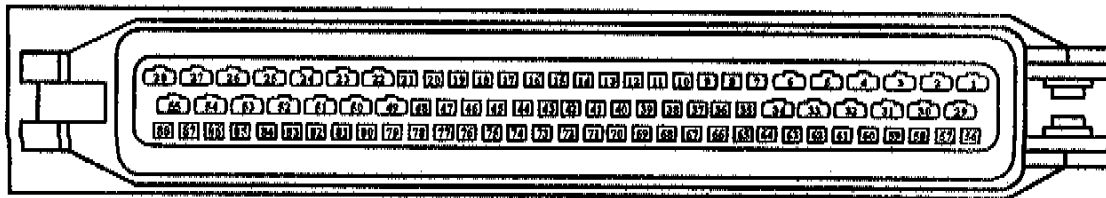



Technical Service Information

RETRIEVING FAULT CODES

The BMW Diagnostic Tool is *required* to retrieve the fault codes that are stored in the control unit. The diagnostic tool has the ability to retrieve codes, clear codes and activate individual components, and is adaptable to 3 Series, 5 Series, 7 Series and 8 Series vehicles equipped with 4HP-22/24, 4L30-E, 5HP-18, 5HP-19, and 5HP-30. The BMW Diagnostic Tool can be purchased from:

Mario Aristides Phone - (305) 666-3544, Fax - (305) 666-8238

BMW ZF-5HP-30 FAULT CODE CHART

<i>Code</i>	<i>Description</i>	<i>Possible Causes</i>
01	Pressure Regulator, EDS 2 - Pin 1	Questionable signal, or break or short in wiring
02	Park-Neutral Lock Solenoid - Pin 2	Break or short in wiring
04	Pressure Regulator, EDS 4 - Pin 4	Questionable signal, or break or short in wiring
05	Pressure Regulator, EDS 1 - Pin 5	Questionable signal, or break or short in wiring
08	Selector Lever Position L2 - Pin 8	Vehicle acceleration detected while selector lever in P or N position, or engine has been started even though EGS control unit has not detected a selector lever position of P or N
09	Selector Lever Position L3/L4 - Pins 37 and 9	Engine has been started even though EGS control unit has not detected a selector lever position of P or N
0C	Program Selector Switch - Pins 12, 13 and 45	Short in wiring, or more than one program selector switch input is applied to ground
10	Rotational Speed Sensor, Turbocharger Pins 16 and 44	No input, or incorrect engine speed information
12	Kickdown Switch - Pin 18	Questionable signal
13	ASC Monitoring - Pin 19	ASC operation has been detected while selector lever was in Park or Neutral position
16	TOT Sensor - Pins 21 and 22	Resistance of TOT Sensor not within permissible range
1A	Battery Voltage Supply - Pin 26	Break in wiring
1D	Pressure Regulator, EDS 3 - Pin 29	Questionable signal, or break or short in wiring
1E	MV 1 Solenoid - Pin 30	Break or short in wiring, or defective winding in solenoid
20	MV 3 Solenoid - Pin 32	Break or short in wiring, or defective winding in solenoid
21	MV 2 Solenoid - Pin 33	Break or short in wiring, or defective winding in solenoid
24	Selector Lever Position L1 - Pin 36	Break or short in wiring, or defective sensor
2A	Output Speed Sensor signal and Stall Speed signal - Pins 13 and 42	No input, or incorrect engine speed information
33	Pressure Regulator, EDS 5 - Pin 51	Questionable signal, or break or short in wiring
34	Power Supply to transmission - Pin 52	Break or short in wiring

Copyright © 1998 ATSG

BMW ZF-5HP-30 FAULT CODE CHART

Code	Description	Possible Causes
36	Power Supply - Pin 54	Power Supply less than 9 volts at engine speeds greater than 1600 RPM
64	Speed Monitoring	Faulty Speed Sensor signal, or slip in Transmission
65	EPROM - Checksum	Program memory in Transmission Control Unit faulty
66	Incorrect Program Checksum	Program memory in Transmission Control Unit faulty
67	Transmission Relay - Pin 52	Pickup and dropout times too long
68	Over-revving Lock	Engine RPM greater than 6816 has been detected
69	Speed Monitoring	Faulty Speed Sensor signal, or slip in Transmission
6A	Speed Monitoring	Faulty Speed Sensor signal, or slip in Transmission
96	CAN Timeout 1	CAN signal not sent during initialization (Ignition On)
97	CAN Timeout 2	CAN signal not sent during operation
98	CAN Bus monitoring	Values in CAN RAM are not updated
99	CAN status fault	
9A	CAN throttle valve information	DME detects faulty throttle valve signal
9B	CAN load signal information	DME detects faulty load signal
9C	CAN engine intervention	DME cannot carry out reduction in engine torque desire by the EGS, or DME has different requirements compared to other CAN users
9D	CAN engine temperature info	DME detects faulty engine temperature signal

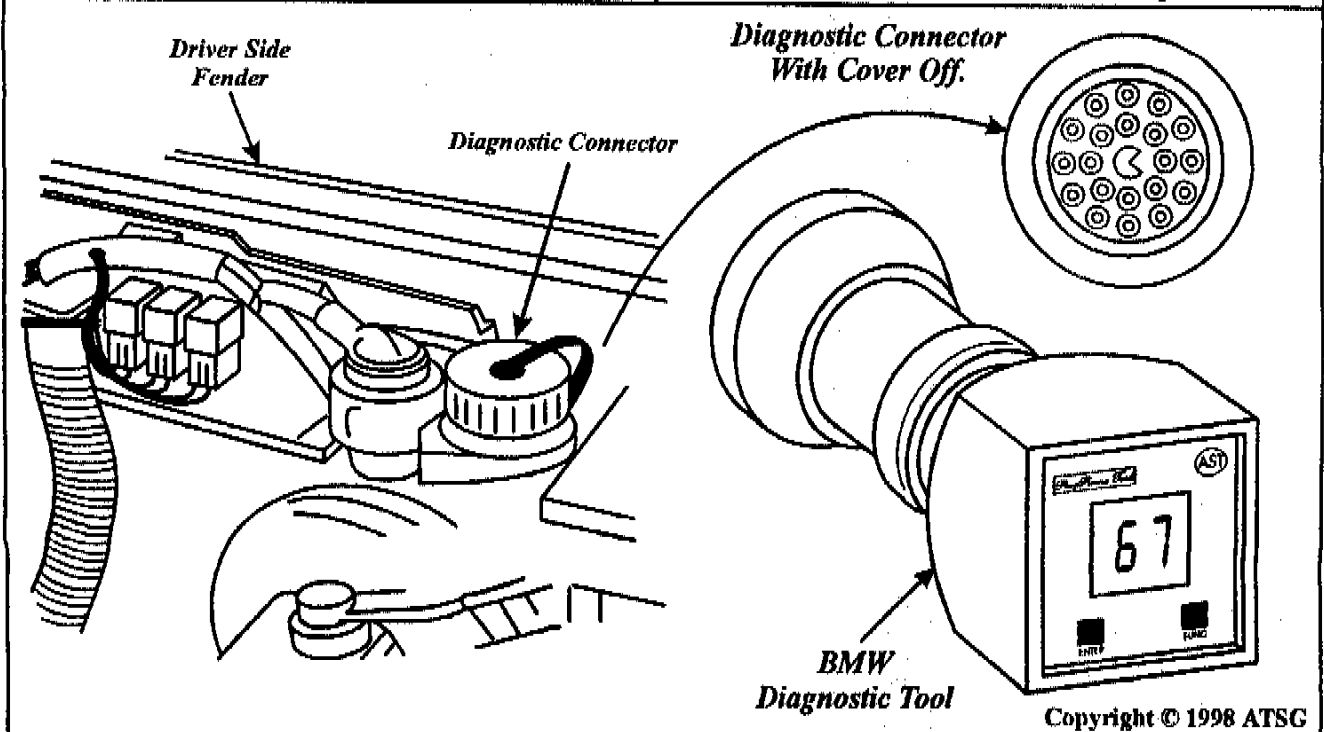

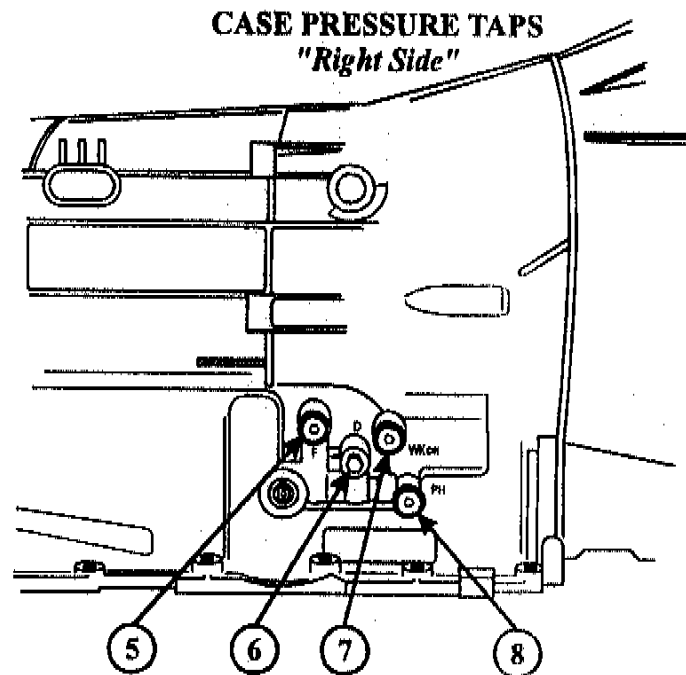
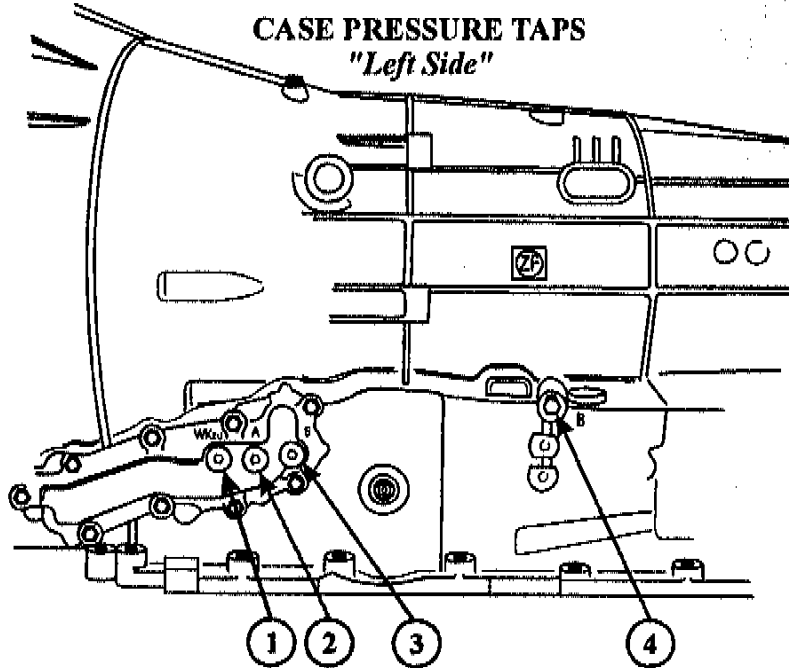

1. *WKzu = Converter Clutch ON Pressure.*
2. *A = "A" Clutch Pressure.*
3. *S = Cooler Pressure.*
4. *B = "B" Clutch Pressure (Must Drill and Tap for Access).*
5. *F = "F" Clutch Pressure.*
6. *D = "D" Clutch Pressure (Must Drill and Tap for Access).*
7. *WKoff = Converter Clutch OFF Pressure.*
8. *PH = Line Pressure.*

Copyright © 1998 ATSG



Technical Service Information

BMW ZF 5-HP-30 NO REVERSE

COMPLAINT: 1991 and later BMW vehicles equipped with the ZF 5-HP-30 transmission may exhibit a no reverse condition, when selector lever is placed into reverse.

CAUSE: The cause may be, the .236" diameter checkball located in the bathtub in the channel plate has blown through the spacer plate, which will now exhaust "F" clutch (Reverse) oil pressure.

CORRECTION: Install a .250" diameter plastic checkball into the bathtub in the channel plate as shown in Figure 1. The holes in the spacer plate over the bathtub measure .198" and the larger diameter checkball will greatly decrease the probability of this condition occurring again. There is also ample room in the bathtub for the increased diameter checkball to perform its duties. Refer to Figure 1. Figure 2 illustrates the location of the only other checkball in this unit and do not install checkball in the location marked "X".

SPECIAL NOTE: The checkball wearing and blowing through the spacer plate causing the loss of reverse, may also have caused some damage to the "C" Clutch which is also on in reverse. This condition has also been known to create damage to the "A"/"C" Clutch Housing as well. If the clutch housing has been severely damaged, aluminum material will be evidenced in the bottom pan upon inspection.

When the unit is removed and the "A"/"C" Clutch Housing is dis-assembled, it is not uncommon for the unit to set for over a week waiting on parts. When re-assembling it is very easy to *mis-assemble* the "B" Clutch Hub on top of the retaining snap ring for the "A" Clutch pack. This mis-assembly will create a neutralizing on the 3-4 upshift, and the Trans light will begin flashing.

Ensure that you assemble the "B" Clutch Hub on top of the "A" Clutch stack, and then install the "A" Clutch Pressure Plate and snap ring, as shown in Figure 3.

Copyright © 1998 ATSG

ZF-5HP-30 CHANNEL PLATE LOWER VALVE BODY SIDE

*Replace the original ball with
a plastic .250" (6.35mm) ball.*

*Original
.236" Diameter*

*.039"
Flat Orifice*

*.048"
Flat Orifice*

*.048"
Flat Orifice*

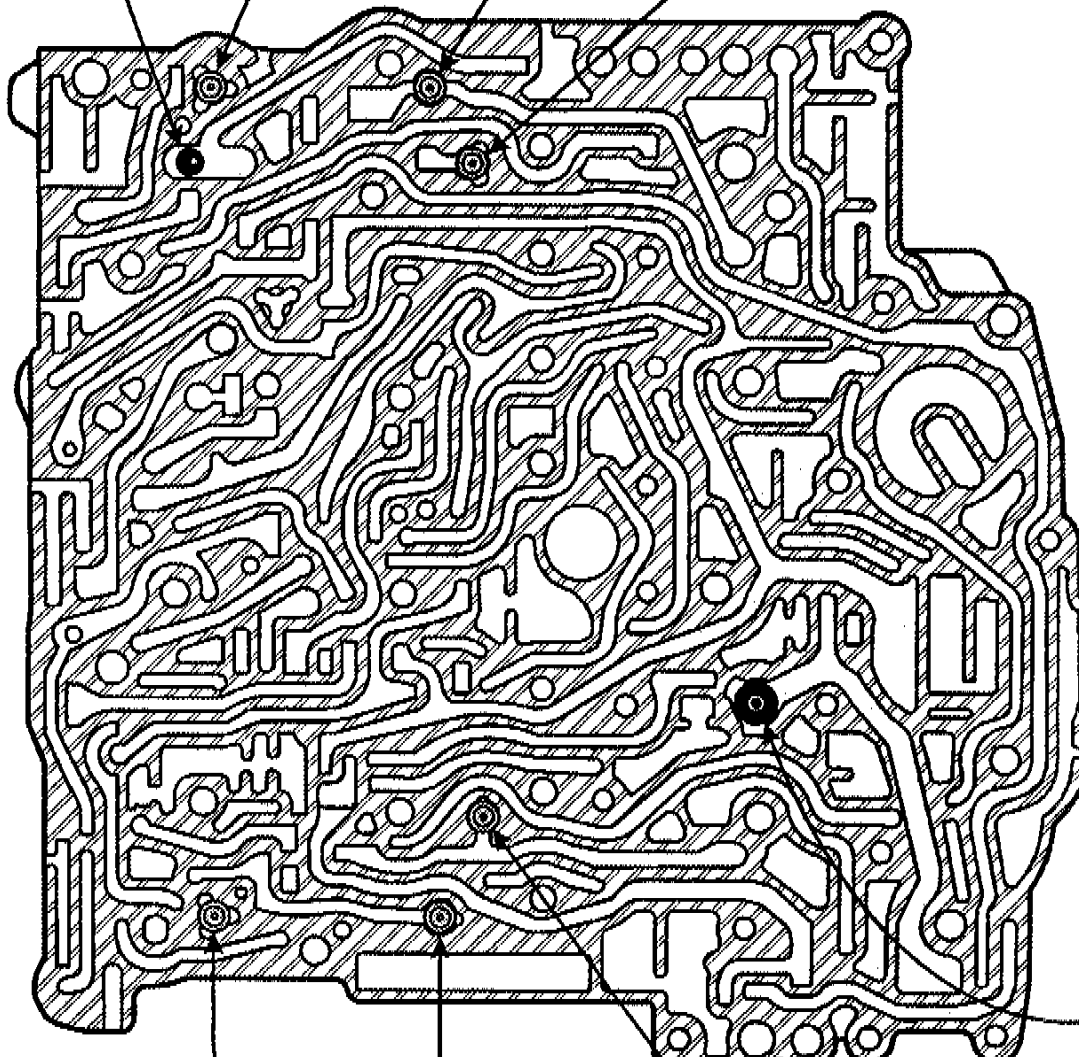

**PLASTIC VALVE
AND SPRING**

*.039"
Flat Orifice*

*.048"
Flat Orifice*

*.067"
Flat Orifice*

Copyright © 1998 ATSG

Figure 1

UPPER REAR VALVE BODY CHECKBALL LOCATION

*Only One .250" (6.35mm) ball is located here.
Do Not install a ball in the pocket marked X.*

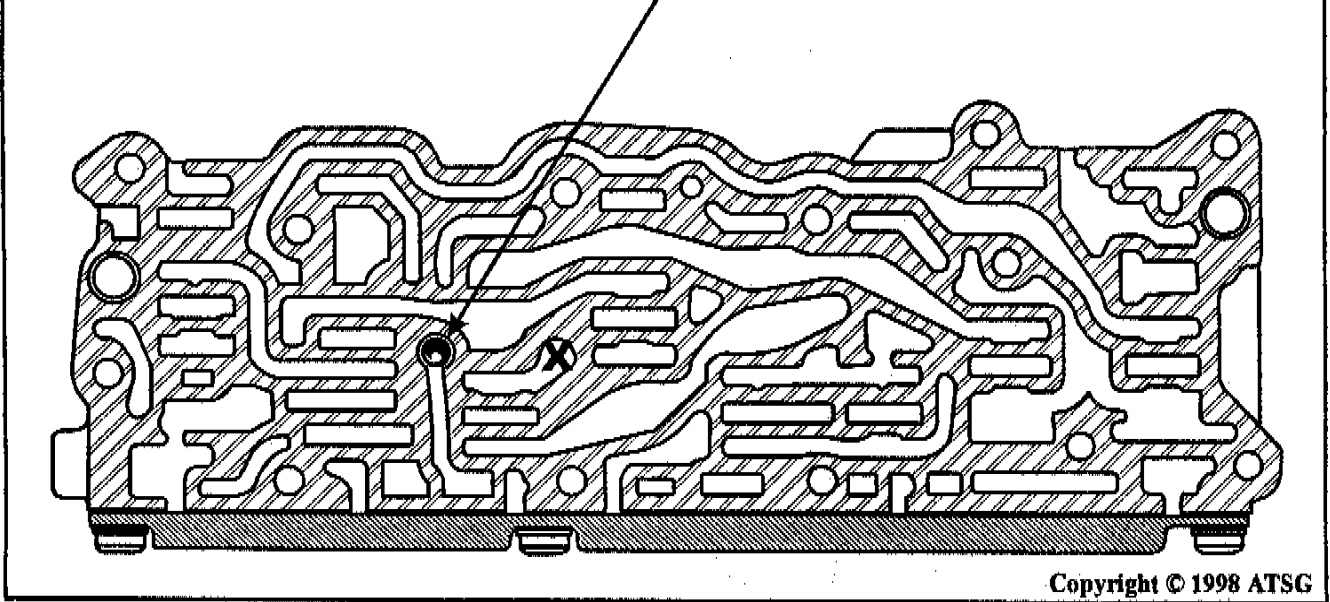

Copyright © 1998 ATSG

Figure 2

"A"/"C" CLUTCH HOUSING COMPONENTS

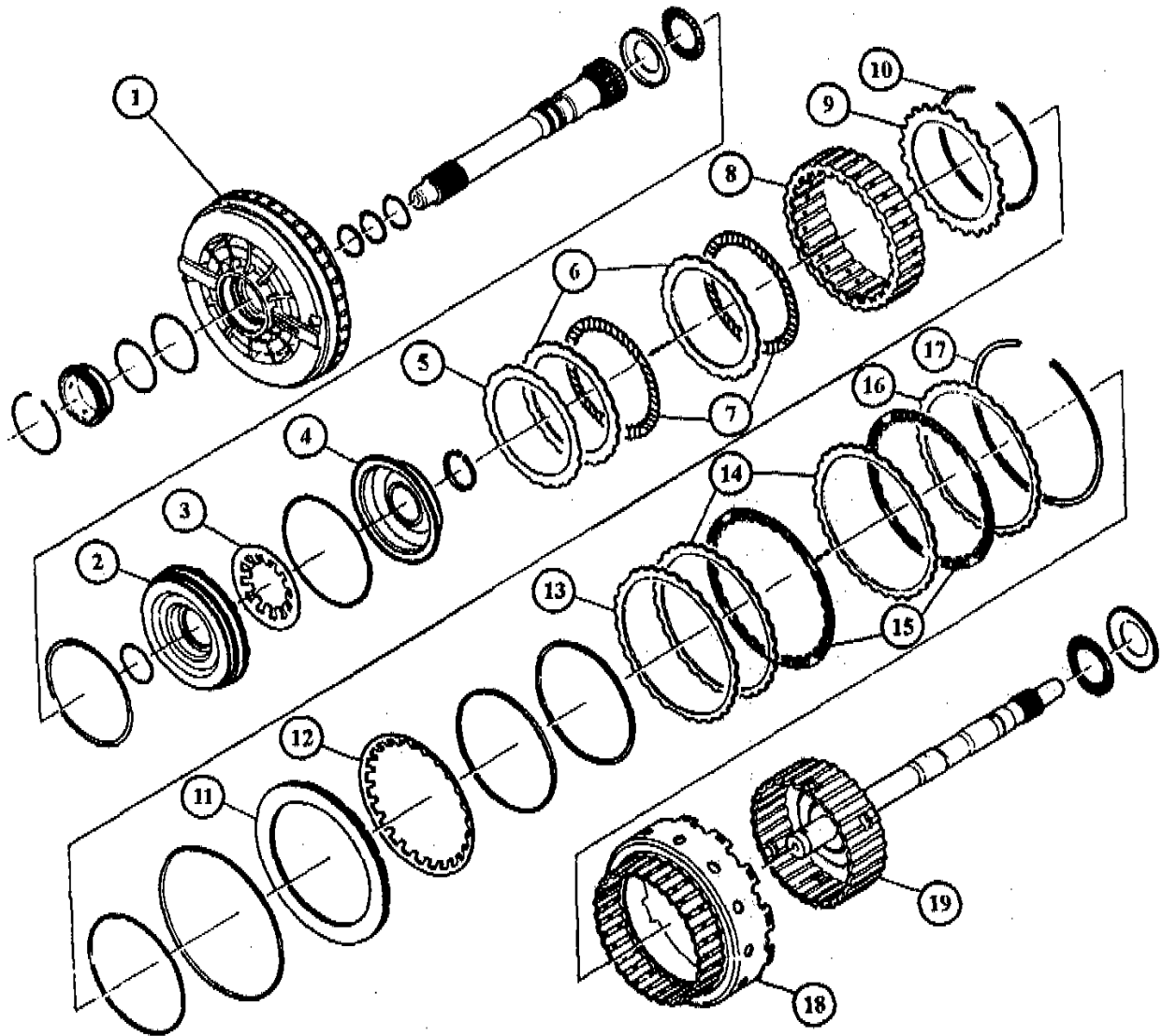

1. "A"/"C" Clutch Housing Assembly
2. "A" Clutch Apply Piston
3. "A" Clutch Bellville Return Spring
4. "A" Clutch Piston Oil Dam
5. "A" Clutch Cushion Plate
6. "A" Clutch Steel Plates (5 Required)
7. "A" Clutch Friction Plates (5 Required)
8. "B" Clutch Hub
9. "A" Clutch Pressure Plate
10. "A" Clutch Pressure Plate Snap Ring

11. "C" Clutch Apply Piston
12. "C" Clutch Apply Piston Return Spring
13. "C" Clutch Cushion Plate
14. "C" Clutch Steel Plates (3 Required)
15. "C" Clutch Friction Plates (3 Required)
16. "C" Clutch Pressure Plate
17. "C" Clutch Pressure Plate Snap Ring
18. "C" Clutch Hub
19. "A" Clutch Hub And Input Shaft

Copyright © 1998 ATSG

Figure 3